

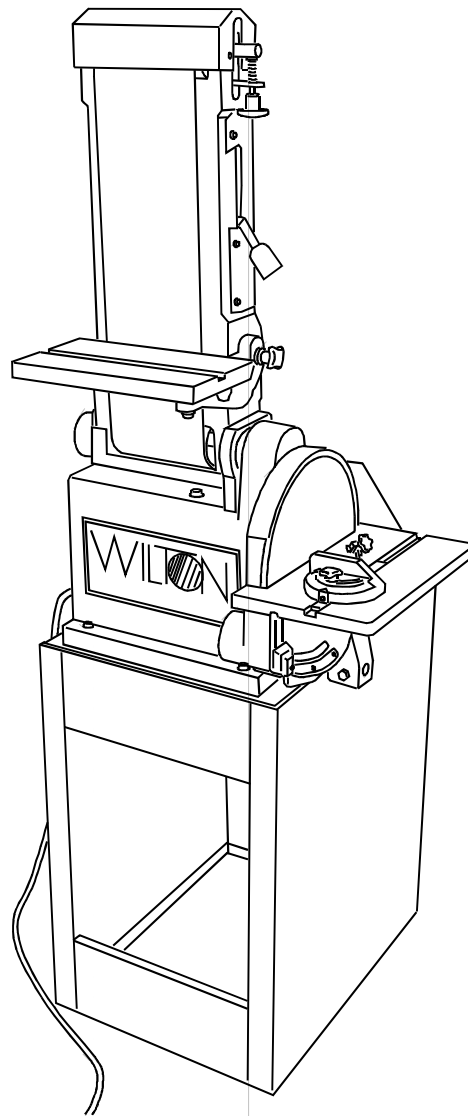

Operating Instructions — Parts Manual
Wilton Belt and Disc Sanding Machine
Model: 4210



WMH TOOL GROUP
2420 Vantage Drive
Elgin, Illinois 60123
Ph.: 800-274-6848
www.wmhtoolgroup.com

Part No. 5511717
Revision A8 02/05
Copyright © WMH Tool Group

This manual has been prepared for owners of Wilton Model 4210 Belt and Disc Sanding Machine. Its purpose is to promote safety through the use of accepted operating and maintenance procedures. To obtain maximum life and efficiency from your Belt and Disc Sander and to aid in using it safely, please read this manual thoroughly and follow the instructions carefully.

Warranty

WMH Tool Group warrants every product it sells. If one of our tools needs service or repair, one of our Authorized Repair Stations located throughout the United States can give you quick service.

In most cases, any one of these WMH Tool Group Repair Stations can authorize warranty repair, assist you in obtaining parts, or perform routine maintenance and major repair on your JET, Wilton, Powermatic, or Performax tools.

For the name of an Authorized Repair Station in your area, please call 1-800-274-6848, or visit www.wmhtoolgroup.com

More Information

WMH Tool Group is consistently adding new products to the line. For complete, up-to-date product information, check with your local WMH Tool Group distributor, or visit www.wmhtoolgroup.com

WMH Tool Group Industrial Metalworking Warranty

WMH Tool Group makes every effort to assure that its products meet high quality and durability standards and warrants to the original retail consumer/purchaser of our products that each product be free from defects in materials and workmanship as follows: TWO (2) YEAR LIMITED WARRANTY* ON ANY MECHANICAL COMPONENT, ONE (1) YEAR LIMITED WARRANTY ON ANY ELECTRICAL COMPONENT. WMH This Warranty does not apply to defects due directly or indirectly to misuse, abuse, negligence or accidents, normal wear-and-tear, repair or alterations outside our facilities, or to a lack of maintenance.

WMH TOOL GROUP LIMITS ALL IMPLIED WARRANTIES TO THE PERIOD SPECIFIED ABOVE, FROM THE DATE THE PRODUCT WAS PURCHASED AT RETAIL. EXCEPT AS STATED HEREIN, ANY IMPLIED WARRANTIES OR MERCHANTABILITY AND FITNESS ARE EXCLUDED. SOME STATES DO NOT ALLOW LIMITATIONS ON HOW LONG THE IMPLIED WARRANTY LASTS, SO THE ABOVE LIMITATION MAY NOT APPLY TO YOU. WMH TOOL GROUP SHALL IN NO EVENT BE LIABLE FOR DEATH, INJURIES TO PERSONS OR PROPERTY, OR FOR INCIDENTAL, CONTINGENT, SPECIAL, OR CONSEQUENTIAL DAMAGES ARISING FROM THE USE OF OUR PRODUCTS. SOME STATES DO NOT ALLOW THE EXCLUSION OR LIMITATION OF INCIDENTAL OR CONSEQUENTIAL DAMAGES, SO THE ABOVE LIMITATION OR EXCLUSION MAY NOT APPLY TO YOU.

To take advantage of this warranty, the product or part must be returned for examination, postage prepaid, to an Authorized Repair Station designated by our office. Proof of purchase date and an explanation of the complaint must accompany the merchandise. If our inspection discloses a defect, we will either repair or replace the product, or refund the purchase price if we cannot readily and quickly provide a repair or replacement, if you are willing to accept a refund. We will return repaired product or replacement at WMH Tool Group's expense, but if it is determined there is no defect, or that the defect resulted from causes not within the scope of WMH Tool Group's warranty, then the user must bear the cost of storing and returning the product. This warranty gives you specific legal rights; you may also have other rights, which vary from state to state.

WMH Tool Group sells through distributors only. WMH Tool Group reserves the right to effect at any time, without prior notice, those alterations to parts, fittings, and accessory equipment, which they may deem necessary for any reason whatsoever.

* WMH Tool Group Industrial Metalworking's 2 year limited warranty is based on one 8-hour work shift or 2080 hours per year. The warranty period is good for 2 years of a total of 4160 hours whichever comes first.

Table of Contents

Cover Page	1
General Specifications	4
Operating Precautions	5
Introduction	7
Operating Instructions	9
Maintenance	11
Wiring Diagram	14
Troubleshooting	16
Replacement Parts	17
Wiring Diagram	21

General Specifications

The Wilton Model 4210 Belt and Disc Sanding Machine is ideal for all shops. This versatile machine can be used to grind, sand, finish, and contour all types of parts including metal, wood, plastic, and composite materials. Because of these capabilities, the Wilton sander eliminates the need for multiple machines to perform the same tasks.

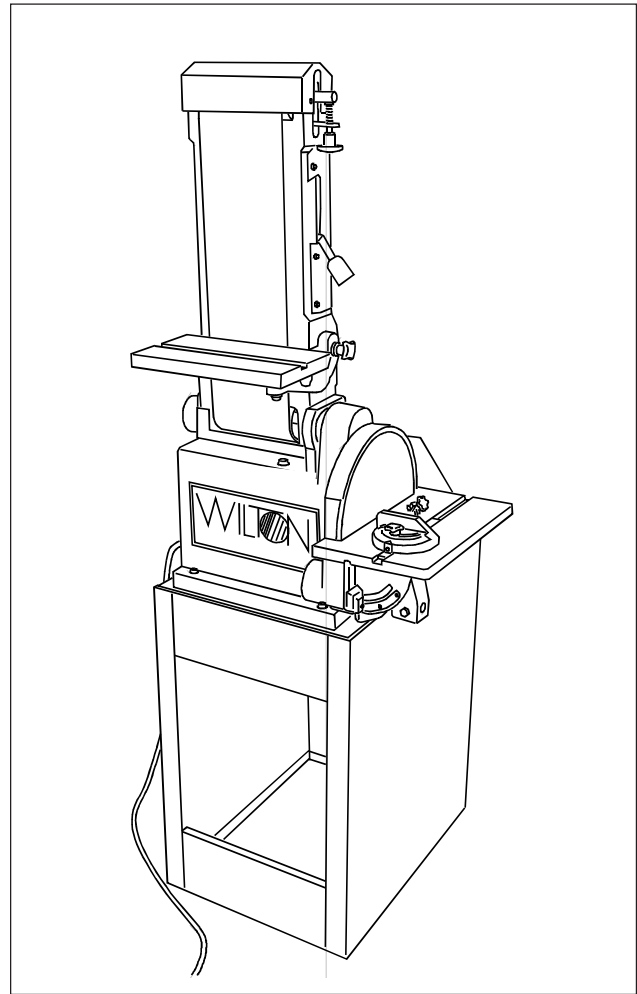

Specifications

Wilton Belt/Disc Sander, Model 4210

Belt Size	6" x 48"
Disc Size	10"
Motor Horsepower Voltage	1 HP 115/230 Vac (pre-wired for 115 Vac)
Switch	Removable Safety Key
Platen	Cast Iron
Tables	Cast Iron (2)
Belt Speed	1650 SFPM
Disc Speed	2100 RPM
Dust Collection Shrouds	Two (standard)
Weight	120 lbs.



WARNING

General Machinery Cautions

- Misuse of this machine can cause serious injury.
- For safety, machine must be set up, used and serviced properly.
- Read, understand and follow instructions in the operator's and parts manual which was shipped with your machine.

When setting up machine:

- Always avoid using machine in damp or poorly lighted work areas.
- Always be sure machine is securely anchored to the floor.
- Always keep machine guards in place.
- Always put start switch in "OFF" position before plugging in machine.

When using machine:

- Never operate with machine guards missing.
 - Always wear safety glasses with side shields (See ANSI Z87.1)
 - Never wear loose clothing or jewelry.
 - Never overreach — you may slip and fall into the machine.
 - Never leave machine running while you are away from it.
 - Always shut off the machine when not in use.
- When servicing machine:
- Always unplug machine from electrical power while servicing.
 - Always follow instructions in operators and parts manual when changing accessory tools or parts.
 - Never modify the machine without consulting Wilton Corporation.

You — the stationary power tool user — hold the key to safety.

Read and follow these simple rules for best results and full benefits from your machine. Used properly, Wilton's machinery is among the best in design and safety. However, any machine used improperly can be rendered inefficient and unsafe. It is absolutely mandatory that those who use our products be properly trained in how to use them correctly. They should read and understand the Operators and Parts Manual as well as all labels affixed to the machine. Failure in following all of these warnings can cause serious injuries.

Machinery general safety warnings

1. Always wear protective eye wear when operating machinery. Eye wear shall be impact resistant, protective safety glasses with side shields which comply with ANSI Z87.1 specifications. Use of eye wear which does not comply with ANSI Z87.1 specifications could result in severe injury from breakage of eye protection.
2. Wear proper apparel; no loose clothing or jewelry which can get caught in moving parts. Rubber soled footwear is recommended for best footing.
3. Do not overreach. Failure to maintain proper working position can cause you to fall into the machine or cause your clothing to get caught — pulling you into the machine.
4. Keep guards in place and in proper working order. Do not operate the machine with guards removed.
5. Avoid dangerous working environments. Do not use stationary machine tools in wet or damp locations. Keep work areas clean and well lit.
6. Avoid accidental starts by being sure the start switch is "OFF" before plugging in the machine.
7. Never leave the machine running while unattended.
8. Disconnect electrical power before servicing. Whenever changing accessories or general maintenance is done on the machine, electrical power to the machine must be disconnected before work is done.
9. Maintain all machine tools with care. Follow all maintenance instructions for lubricating and the changing of accessories. No attempt shall be made to modify or have makeshift repairs done to the machine. This not only voids the warranty but also renders the machine unsafe.
10. Machinery must be anchored to the floor.
11. Secure work. Use clamps or a vise to hold work, when practical. It is safer than using your hands and it frees both hands to operate the machine.
12. Never brush away chips while the machine is in operation.
13. Keep work area clean. Cluttered areas invite accidents.
14. Remove adjusting keys and wrenches before turning machine on.
15. Use the right tool. Don't force a tool or attachment to do a job it was not designed for.
16. Use only recommended accessories and follow manufacturers instructions pertaining to them.
17. Keep hands in sight and clear of all moving parts and cutting surfaces.
18. All visitors should be kept at a safe distance from the work area. Make workshop completely safe by using padlocks, master switches, or by removing starter keys.
19. Know the tool you are using — its application, limitations, and potential hazards.

General Electrical Cautions

This machine should be grounded in accordance with the National Electrical Code and local codes and ordinances. This work should be done by a qualified electrician. The machine should be grounded to protect the user from electrical shock.

Wire sizes

Caution: for circuits which are far away from the electrical service box, the wire size must be increased in order to deliver ample voltage to the motor. To minimize power losses and to prevent motor overheating and burnout, the use of wire sizes for branch circuits or electrical extension cords according to the following table is recommended:

Conductor length	AWG (American wire gauge) number	
	240 volt lines	120 volt lines
0-50 feet	No. 14	No. 14
50-100 feet	No. 14	No. 12
Over 100 feet	No. 12	No. 8

Safety Requirements for Abrasive Sanding Machines

Abrasive sanding can be hazardous to operators and bystanders. Sanding sparks, chips and dust particles thrown off by the sanding disc can cause serious injury by contact or inhalation. To avoid injuries you must comply with the following safety requirements:

1. Always wear protective eyewear when operating machinery. Eye wear shall be impact resistant, protective safety glasses with side shields which comply with ANSI Z87.1. Use of eye wear which does not comply with ANSI Z87.1 specifications could result in severe injury from breakage of eye protection. See **Figure A**, below.
2. Wear leather safety gloves, arm guards, leather aprons and safety shoes.
3. A dust collection system is recommended, Operator shall also wear a dust mask at all times. See **Figure B**, below.
4. Additional precautions may be necessary for sanding materials which are flammable or have other hazardous properties. You should always consult the manufacturer of such materials for instructions on sanding and handling.
5. Do not force or jamb the workpiece into the sanding disc.
6. Before sanding, always allow the motor to come up to operating speed, then check the sanding disc

for wobble, runout, or any unbalanced condition. If the disc is not operating accurately and smoothly, immediately stop the motor and make repairs before attempting any sanding operations.

7. Abrasive discs must be stored in a controlled environment area. Relative humidity should be 35% to 50% and the temperature should be between 60 and 80 degrees Fahrenheit. Failure to do so could cause premature disc failure.
8. Examine the face of the sanding disc carefully. Excessive sanding which wears down to the backing material can tearing of the disc. Never use a disc which shows backing, nicks or cuts on the surface or edge or damage due to creasing or poor handling.
9. When installing a new disc, be certain the disc is accurately centered on the drive wheel. Failure to do so could cause a serious unbalanced condition.
10. Always present the workpiece to the wheel while resting the workpiece firmly on the table. Failure to do so could result in damage to the workpiece or throwing of the workpiece off the wheel.
11. Safety shoes which comply with ANSI Z41.1 shall be worn. See **Figure C**.
12. Personal hearing protection such as ear plugs or ear muffs shall be used to protect against the effect of noise exposure. See **Figure D**.

6

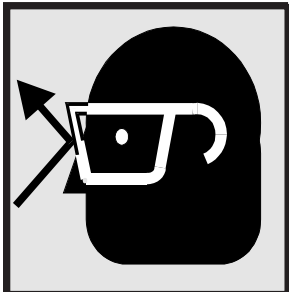

Figure A

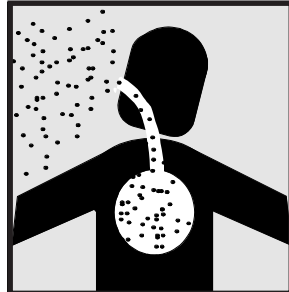

Figure B

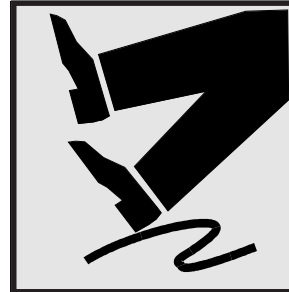

Figure C

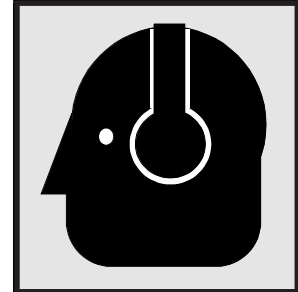

Figure D

Introduction

This manual includes operating and maintenance instructions for the Wilton Model 4210 Belt and Disc Sander. This manual also includes parts listings and illustrations of replaceable parts.

Belt and Disc Sander Features

Figures 1 and 2 depict the main features of the Wilton Model 4210 Belt and Disc Sander. (Specifications for the sanding machine are provided on page 3.)

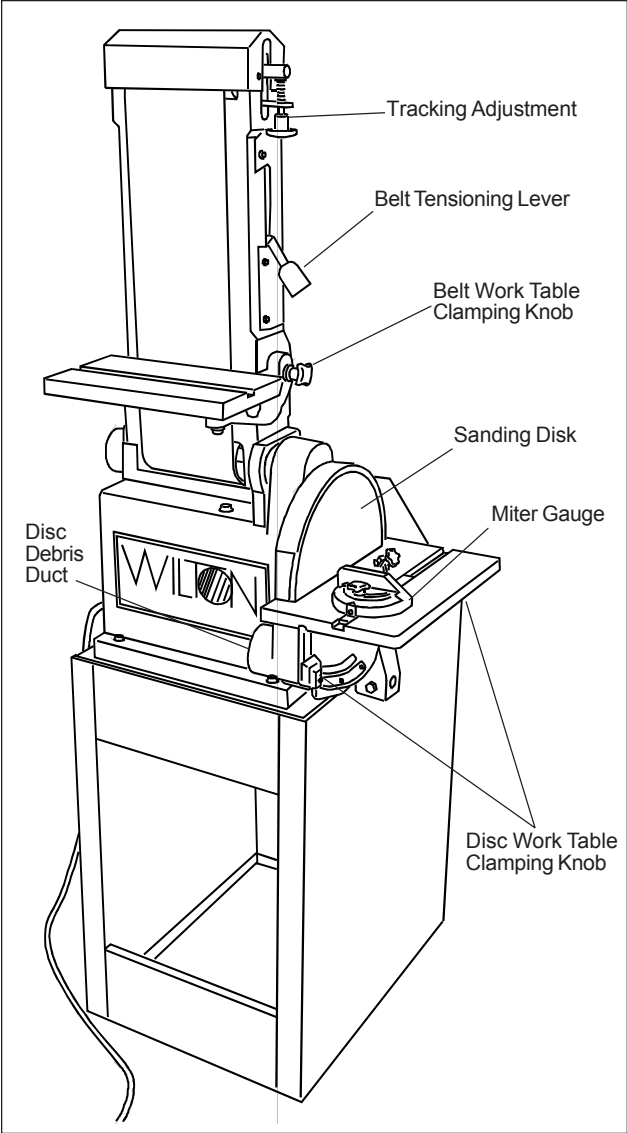

Figure 1: Belt and Disc Sander Features (Right Side View)

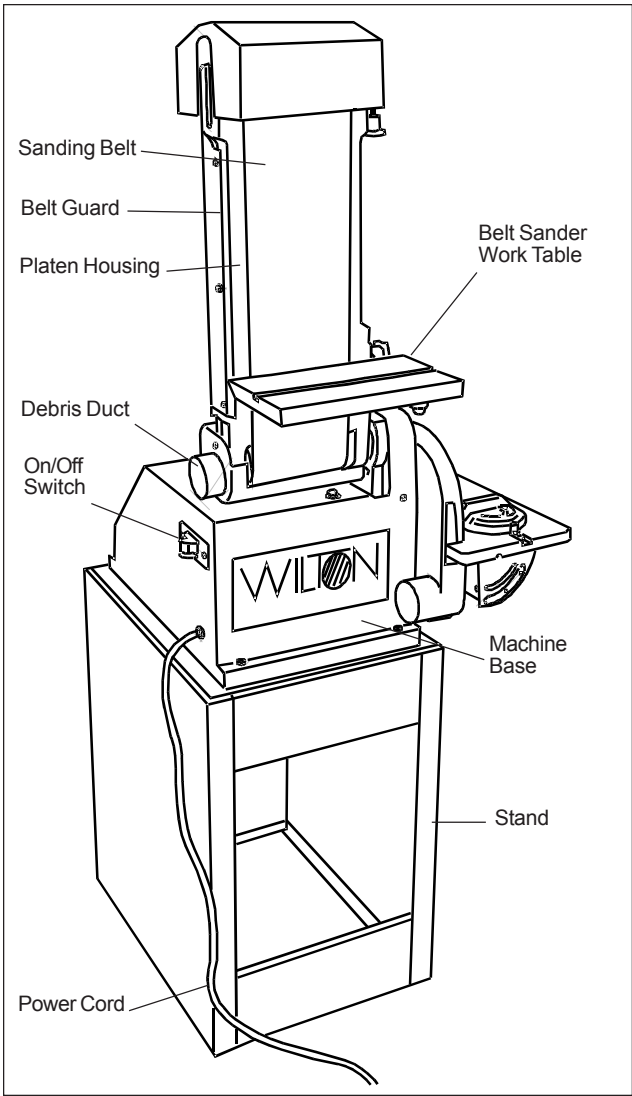

Figure 2: Belt and Disc Sander Features (Left Side View)

The sander has both a sanding belt and a sanding disc for use on a variety of work pieces and materials.

The platen housing for the belt sander can be positioned vertically or horizontally. When in the vertical position, the drum at the upper end of the platen housing can be used for contouring. A tracking adjustment mechanism for the sanding belt is provided at the upper end of the platen housing.

The platen housing has a lever that is used to apply tension to the sanding belt. The sanding belt is easily replaced by releasing the tension lever, removing a sanding shroud and dust collection duct at the bottom of the platen housing, and slipping the belt from the belt sander drums. Installation is the reverse of the removal steps.

The disc sander consists of an aluminum disc onto which is installed an adhesive-backed sanding and other abrasive discs. The disc is contained within a ducted shroud.

The sanding disc can be replaced by removing the table and a cover over the lower portion of the disc. If desired, the aluminum disc can be removed from its drive shaft to ease replacement of the sanding disc.

The drive motor for the belt and disc sander is attached to the underside of the machine base. An ON/OFF switch is mounted on the machine base on the side opposite the disc sander. Electrical wiring for the motor enters the machine base below the ON/OFF switch and is routed to the switch and motor inside the machine base.

The belt and disc sander is driven by V-belts connected to the drive motor. A pulley on the motor shaft drives a V-belt that drives a dual-groove pulley on an idler shaft. A second V-belt is installed in the second groove of the dual-groove pulley and connects to a pulley on belt sander drive shaft.

The aluminum sanding disc is driven off the end of the idler shaft. A shaft connected to the second V-belt pulley drives the belt sander drive drum.

The belt and disc sander is mounted on a stand that can be secured to the floor to stabilize the machine. The stand has a door for access to the fasteners for the machine base.

Installation and Setup

Mounting

It is recommended that the belt and disc sander be secured to the floor for safe operation. The machine stand has mounting holes in a flange on the inside of stand enclosure. The stand can be secured to the floor using these mounting holes.

Electrical Connection

Refer to the **Wiring Data** section for wiring information. Electrical power should be connected by a qualified electrician. Observe local electrical codes when connecting and grounding the machine.

Operation

This section defines the controls and other features with which the operator should be familiar. Refer to Figures 3 and 4 for some typical sander operations.

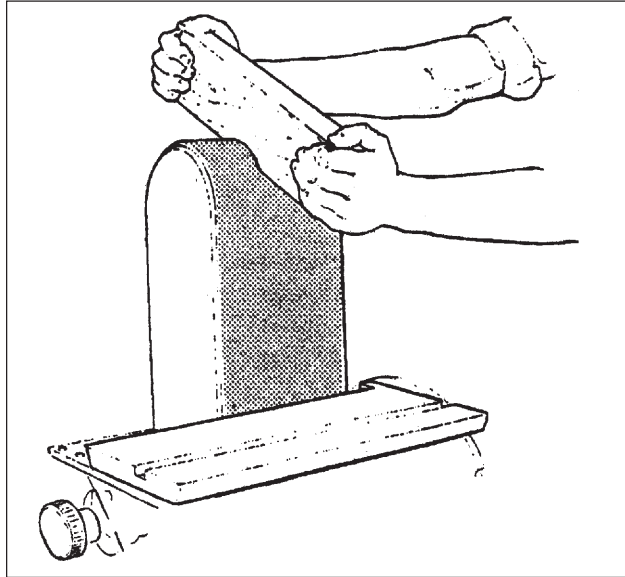

Figure 3. Contouring with Belt Sander

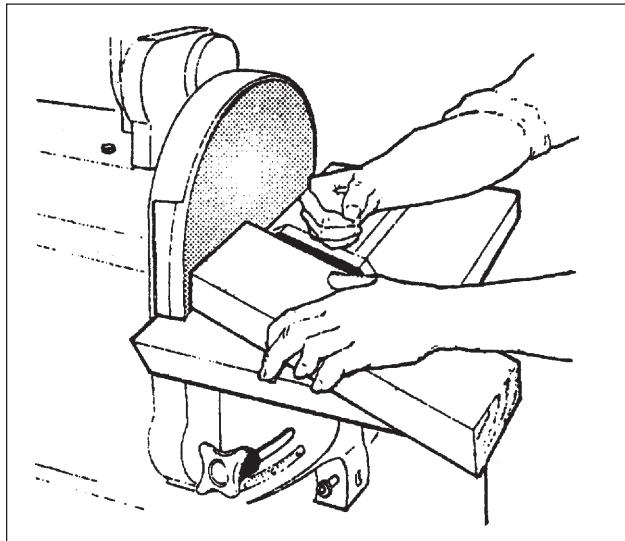

Figure 4. Sanding using Disc Sander

Controls

The ON/OFF switch is located on the side of the machine base (refer to Figure 5).

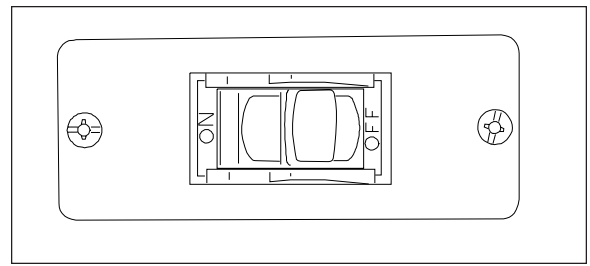

Figure 5. ON/OFF Switch

Miter Gauge

A miter gauge is provided with the machine and can be used on either the belt sander or disc sander work tables. The angle of the miter gauge can be adjusted up to 45 degrees to accommodate angular work piece surfaces.

Adjustments

Adjusting Belt Tracking

The tracking of the sanding belt may require adjustment after changing the belt. The belt housing has a tracking adjustment mechanism (Figure 6) that is used to adjust tracking.

1. Start the machine.
2. Check tracking of the sanding belt. The belt should track at the center of the drums.
3. Adjust belt tracking by turning the adjustment knob. Turn the knob as needed to correct the tracking of the belt.

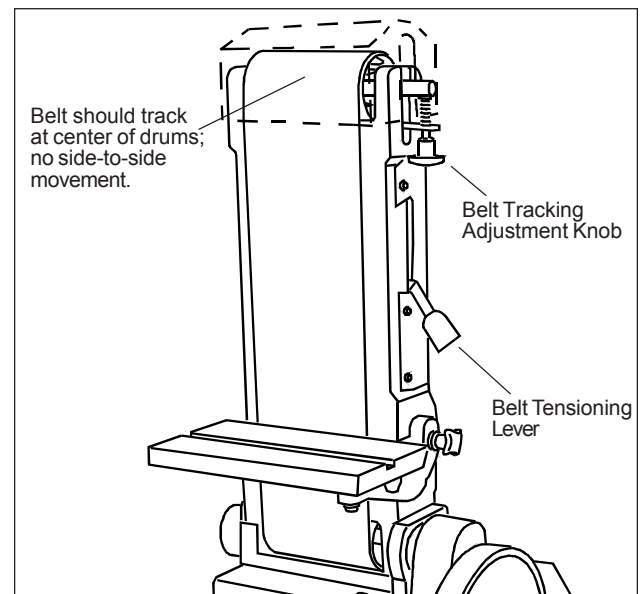

Figure 6. Adjusting Belt Tracking

Adjusting Platen Housing Position

The sanding belt can be operated with the platen housing horizontal, vertical, or at any angle in between. Change position of the platen housing as follows:

WARNING: DISCONNECT ELECTRICAL POWER TO THE MACHINE BEFORE PERFORMING ANY MAINTENANCE.

1. Disconnect electrical power.
2. Remove four screws (52) and pulley cover (12).
3. Using an open end wrench, loosen two hex screws (13) (refer to Figure 7).
4. Move the platen housing to the desired position. When the platen housing is to be placed in the horizontal position, lower the platen housing onto stop screw (28) on the machine base.
5. If the stop requires adjustment, loosen jam nut (29), adjust stop screw (28) to desired position, and tighten nut (29).
6. Tighten two hex screws (13).
7. Install pulley cover (12) and secure with four screws (52).
8. Start the machine to check operation.

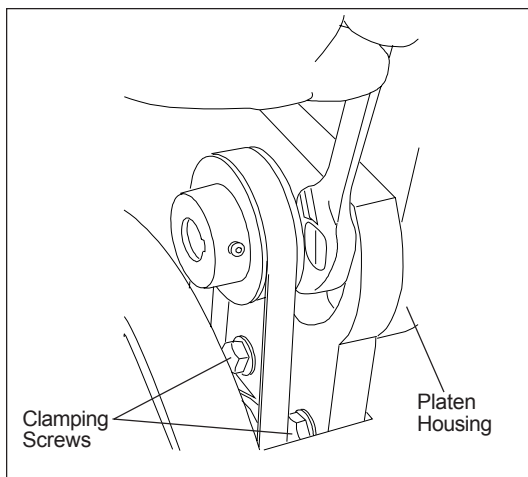

Figure 7. Platen Housing Clamping Screws

Adjusting the Sander Tables

The belt and disc sander tables can be adjusted from 0 to 45 degrees to accommodate the work piece.

Disc Table

1. To change the disc table angle, loosen the knob on the left side of the table (refer to Figure 8).
2. Move the table to the desired angle.
3. Tighten the knob to secure the table.

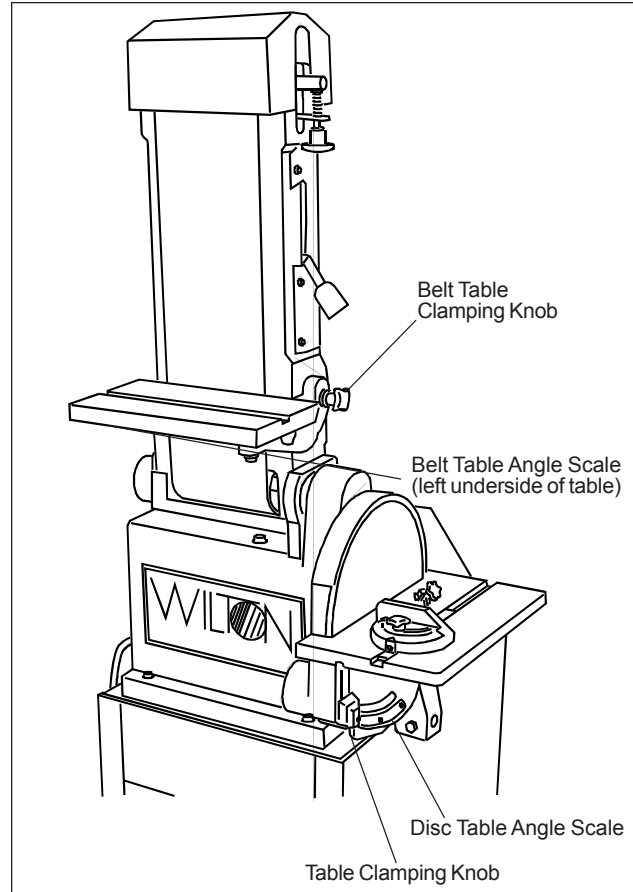

Figure 8. Adjusting Sander Table Angle

Belt Table

1. To change the belt table angle, loosen the knob on the right side of the platen housing (refer to Figure 8).
2. Move the table to the desired angle.
3. Tighten the knob to secure the table.

Maintenance

This section provides procedures required to maintain the belt/disc sander. The numbers in parentheses throughout the manual correspond with reference numbers for parts shown in the exploded views in the **Replacement Parts** section.

Lubrication

The bearings used in the sanding machine are sealed, pre-lubricated bearing. The bearings do not require periodic lubrication.

Cleaning

Periodically use a vacuum cleaner to remove sanding debris from the machine. In hard to reach areas, brush the debris loose while vacuuming.

Replacing the Sanding Belt

WARNING: DISCONNECT ELECTRICAL POWER TO THE MACHINE BEFORE PERFORMING ANY MAINTENANCE.

1. Disconnect electrical power.
2. Position sanding belt platen (4) in the vertical position. Remove eight screws (97) and guard (96).
3. Remove screw (76) and guard (75).
4. Move tensioning lever (50) downward to slacken sanding belt (79).

Refer to Figure 9. Slip sanding belt off drums (5) and (39).

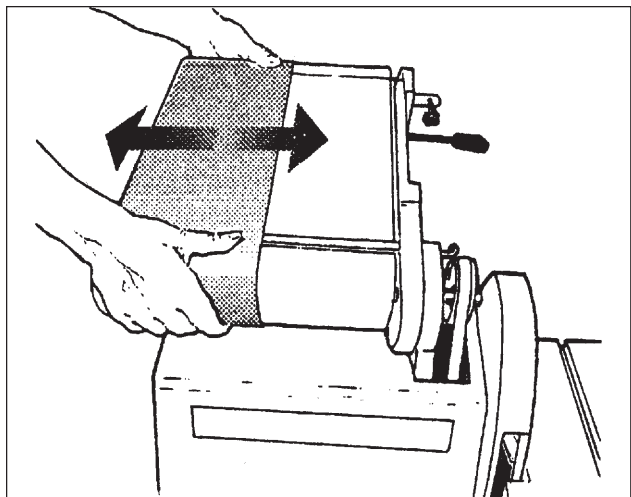

Figure 9. Replacing Sanding Belt

1. Install replacement sanding belt on drums. Position edges of sanding belt evenly on the drums.
2. Lift tensioning lever to tighten sanding belt on drums.
3. Install guard (75) and secure with screw (76).
4. Install guard (96) and secure with eight screws (97).
5. Connect electrical power and operate machine to check operation.
6. If belt does not track properly, adjust tracking (refer to **Adjusting Belt Tracking**).

Replacing the Sanding Disc

WARNING: DISCONNECT ELECTRICAL POWER TO THE MACHINE BEFORE PERFORMING ANY MAINTENANCE.

1. Disconnect electrical power.
2. Loosen screw (65). Remove disc table (60).
3. Remove four screws (56) and plate (55) from disc shroud (53).
4. Insert a long T-handle Allen wrench through the side opening in shroud (53) and into set screw (57). Loosen disc set screw (57) and remove disc (58).

WARNING: USE CARE WHEN USING KNIFE TO SEPARATE SANDING DISC (59) FROM DISC (58). INJURY FROM THE KNIFE MAY OCCUR IF THE KNIFE SLIP OR IF SANDING DISC SHOULD SUDDENLY COME FREE.

5. Using a knife, slowly work the tip of the knife blade under sanding disc (59). Slowly work the tip around the circumference of disc (58). Continue to work around the circumference until sanding disc can be separated by hand from disc (58).
6. Remove paper backing from replacement sanding disc (59). Place sanding disc (59) on disc (58). Make sure the sanding disc is placed evenly at the outside diameter of disc (58).
7. Press on the sanding disc to remove any entrapped air and to make sure the sanding disc is adhering to disc (58).
8. Install disc (58) onto shaft (16). Position the disc on the shaft to provide clearance between plate (55) and sanding disc. Tighten set screw (57).

NOTE: There is a close fit between the edge of disc (58) and disc shroud. To ease installation and positioning of the disc, use an L-shaped tool (such as an Allen wrench) under outer edge of the disc to support and position the disc while tightening set screw.

9. Install plate (55) and secure with four screws (56). Check for clearance between plate (55) and the sanding disc.
10. Install table (60) onto rod (74). Position table so it is level and tighten screw (65) against rod (74).
11. Connect electrical power and operate machine to check operation.

Replacing the V-Belts

WARNING: DISCONNECT ELECTRICAL POWER TO THE MACHINE BEFORE PERFORMING ANY MAINTENANCE.

1. Disconnect electrical power.
2. Remove sanding belt table.
3. Remove sanding disc table.
4. Remove sanding disc and shroud.
5. Remove pulley cover. Loosen set screw in pulley.
6. With second person holding belt housing, alternately loosen and remove two screws.
7. Remove V-belt from pulley (11). Remove pulley from shaft while separating assembled belt housing from the machine base.
8. Remove key from sanding belt drum shaft.
9. Loosen set screw in pulley (20).
10. Remove pulley. While removing pulley, slip V-belts from pulley.
11. Remove four screws from base. With assistance of the second person, lift base from stand.

NOTE: Place base on bench. As an alternative, the stand may be used to support the base while removing drive motor screws.

12. Place base on bench with underside of the base facing up.
13. Remove two hex head screws, two nuts, and two washers from the motor base on the shaft side of motor.
14. Loosen (but do not remove) two hex bolts, two nuts, and two washers on the side of motor base opposite the motor shaft.
15. Tip motor enough to provide clearance between end of shaft and wall of base. Remove motor drive belt.
16. With base still on the bench, slip V-belt (15) over end of idler shaft.

NOTE: Install V-belt for sanding belt first, followed by the motor V-belt.

17. Install replacement V-belt over end of motor shaft.
18. Install two hex bolts, two nuts, and two washers in the motor base on the shaft side of motor. Tighten all four hex nuts and hex head screws.

19. Install key in idler shaft with keyway facing up. Install pulley (20) on idler shaft.
20. Install motor V-belt (18) in outermost groove of pulley (20) and on pulley (18) on motor shaft.
21. Position motor belt (18) on idler shaft so it is parallel with the inner wall of the base. Tighten set screw in pulley (20).
22. Place assembled base on stand. Secure with four screws, washers, nuts.

NOTE: Because of the weight of the belt housing, a second person should hold the belt housing in position while installing pulley (10).

23. Hold belt housing in position in bracket (3). Start two screws (13) in threaded holes in platen. Install key (8) in shaft.

NOTE: Because of the length of screws (13), the screws will have to be installed alternately. As the screws are installed, there will be enough clearance to slide the belt drum drive pulley a little at a time onto shaft (8).

24. Alternately install two screws (13). As the screws are tightened, slide pulley (10) onto the idler shaft as allowed by the protrusion of screw heads. Make sure V-belt remains on pulleys (11 and 20).
25. When screws (13) are fully installed, align pulley (20) with pulley (11). Tighten set screw (10).
26. Install shroud (53) on base and secure with four screws and washers.
27. Install pulley cover (12) and secure with two screws.
28. Install disc (58) onto shaft (16) and over key. Position the disc on the shaft to provide clearance between plate (55) and the sanding disc. Using long T-handle Allen wrench, tighten set screw (57).

NOTE: There is a close fit between the edge of disc (58) and the disc shroud. To ease installation and positioning of the disc, use an L-shaped tool (such as an Allen wrench) under the outer edge of the disc to support and position the disc while tightening the set screw.

29. Install plate (55) and secure with four screws (56). Check for clearance between plate (55) and the sanding disc.
30. Install table (60) onto rod (74). Position table so it is level and tighten screw (65) against rod (74).
31. Install assembled table (88).
32. Connect electrical power and operate machine to check operation.

Replacement of Motor

WARNING: DISCONNECT ELECTRICAL POWER TO THE MACHINE BEFORE PERFORMING ANY MAINTENANCE.

1. Disconnect electrical power.
2. Remove four screws from base. With assistance of the second person, lift base from stand.

NOTE: Place base on bench. As an alternative, the stand may be used to support the base while removing drive motor screws.

3. Place base on bench with underside of the base facing up.
4. Remove four hex head screws, nuts, and washers from the motor base.
5. Remove motor V-belt from motor pulley.

6. Remove motor from base.
7. Loosen set screw in pulley (18). Remove pulley.
8. Align set screw in pulley with flat on motor shaft and install pulley. Do not tighten set screw.
9. Install replacement V-belt over end of motor shaft and install motor in base. Secure with four screws, washers and nuts.
10. Install and tighten four hex bolts, nuts, and washers in the motor base.
11. Position pulley (18) on motor shaft so the V-belt is parallel with the inner wall of the base. Tighten set screw in pulley (20) against flat on motor shaft.
12. Place assembled base on stand. Secure with four screws, washers, nuts.
13. Connect electrical power and operate machine to check operation.

Wiring Data

Single phase electrical hook-up

When connecting your machine to single phase power you may be connecting to either 115 or 230 volts, depending upon the motor type provided. Local codes may, or may not, permit the use of a plug type of connection for your machine. Where a plug connection is permitted, the following installation practices must be followed:

1. The plug used must be a grounding type of plug. On a 115 volt single phase connection, the plug must be a three-prong plug with two flat, parallel blades for the power wires and a single rounded or U-shaped prong for the ground connection. On 230 volt single phase connections, the lug must be a three prong plug with two flat blades in tandem to carry the current, and a third round or U-shaped prong for the ground connection.
2. The service branch to which the plug is connected must be a branch with a separate ground wire so the grounding prong of the plug can be connected to ground effectively.

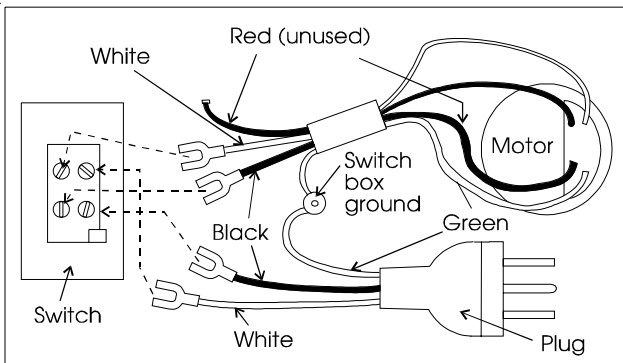

Figure 10: Pictorial diagram for single phase motor, 115 volts w/plug.

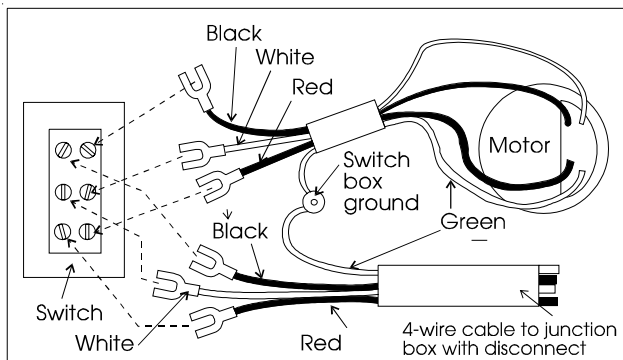

Figure 11: Pictorial diagram for 3-phase motor.

Note: Local electrical codes in many jurisdictions do not allow the use of plug type connections for single phase power when the machine is used in a commercial or industrial establishment.

In these cases you must connect your machine to the service branch using a hard-wired junction box connection.

All Wilton sanders are shipped with the power cable terminating without a plug on the assumption the machine will be hard-wired to its service branch.

Circuit protection

Where the service branch is protected with a fuse or circuit breaker which is too high a value to offer protection to the motor supplied, a fuse or circuit breaker box should be used at the point where the machine connection is made and the time delay fuse or circuit breaker should be a value just slightly higher than the maximum load current draw as specified on the motor plate on the motor.

Correcting motor rotation in single phase motors

Wilton provides single phase motors in both 115 volt and 230 volt configuration. Several motor manufacturers may be used by Wilton for motors of this type.

These motors may, or may not, rotate in the correct direction -- *counter-clockwise* -- when connected to your single phase power source. If, after connection, the motor runs in the correct counter-clockwise direction, the power connection is successful.

CAUTION: IF THE MOTOR RUNS CLOCKWISE WHEN CONNECTED TO YOUR SINGLE PHASE POWER SOURCE, YOU MUST DISCONNECT THE POWER SOURCE, OPEN THE JUNCTION BOX AND FIND THE CORRECT WIRING CONNECTIONS FOR THE MOTOR, OR LOCATE THE WIRING CONNECTIONS REQUIRED ON THE MOTOR PLATE ON THE OUTSIDE OF THE MOTOR.

Different manufacturers provide different wiring configurations for correcting the rotation of the motor armature. Therefore, no wiring diagrams for these motors are provided in this manual. Always consult the motor plate and/or the wiring diagram inside the junction box if rotation direction is not correct.

Connecting Power for 3-phase Motors

1. Be certain the power to the branch you are connecting is off, and locked out, so power cannot be reestablished, accidentally.
2. Connect the ground wires. These wires will be either green, or green with a white trace.
3. Connect the remaining three cable wires to the three power wires in the service branch.
4. Reestablish power to the branch.
5. Turn the machine on. The motor should be turning counter-clockwise, the belt sander should be moving downward, and the disc sander should

be turning clockwise. If this is the case, the machine can be considered wired correctly. If the motor is not turning in the correct direction, take the following corrective action:

6. Disconnect power in the branch again and be certain it cannot be accidentally turned on while you correct the wiring.
7. Reverse ANY TWO of the power wires to the machine.
8. Reestablish power in the service branch to the machine.
9. Turn on the machine again. The motor should now be turning in the correct direction.

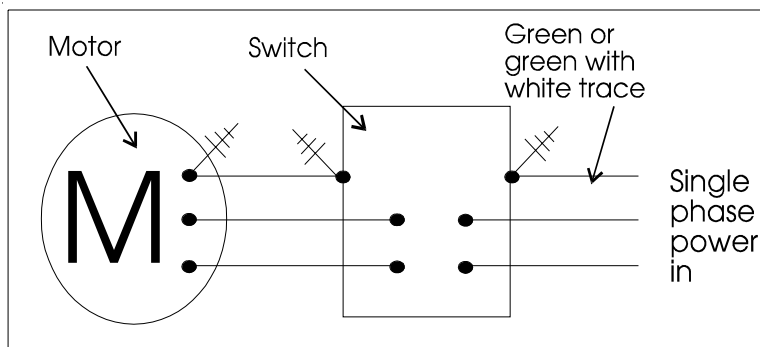

Figure 12: Schematic diagram for single phase motor with 3-wire cable. Note: this schematic provided for use with older Sanders, only. All machines are now shipped with a 4-wire cable whether single phase or 3-phase.

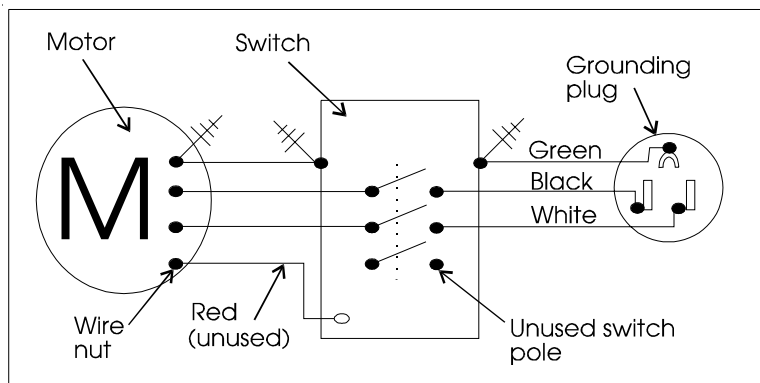

Figure 13: Schematic diagram for single phase motor with 4-wire cable.

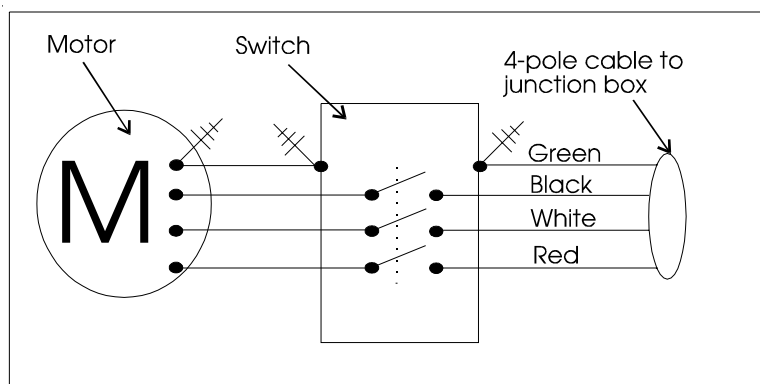

Figure 14: Schematic diagram for 3-phase motor.

Troubleshooting

Fault	Probable Cause	Remedy
Machine does not start.	<ol style="list-style-type: none"> 1. Blown fuse or tripped circuit breaker. 2. Motor failure. 3. Not connected to power source. 4. Motor not wired for correct voltage. 5. Motor not connected to correct voltage source. 	<ol style="list-style-type: none"> 1. Determine reason for blown fuse/tripped breaker (such as a short circuit or motor overload). Correct reason for fault. Replace fuse/reset breaker. 2. Replace motor. 3. Connect to power source. 4. Correct motor wiring. 5. Connect to proper voltage source.
Sanding belt does not track correctly.	<ol style="list-style-type: none"> 1. Sanding belt stretched unevenly. 2. V-belt worn. 3. Pulley worn. 	<ol style="list-style-type: none"> 1. Replace sanding belt. 2. Replace V-belt. 3. Replace pulley.
Abrasive disc separates from disc.	<ol style="list-style-type: none"> 1. Improperly bonded. 	<ol style="list-style-type: none"> 1. Clean residual adhesive from disc. Reapply adhesive-backed disc to clean disc.
Sanding belt slips or stalls when pressure is applied.	<ol style="list-style-type: none"> 1. Abrasive belt tension inadequate. 2. Excessive pressure being applied to platen housing. 3. Motor belt loose. 	<ol style="list-style-type: none"> 1. Tighten sanding belt. 2. Reduce pressure on sanding belt (and platen housing). 3. Tighten motor belt.
Disc stalls when pressure is applied.	<ol style="list-style-type: none"> 1. Motor V-belt loose. 	<ol style="list-style-type: none"> 1. Tighten motor V-belt.
Frequent replacement of sanding belt.	<ol style="list-style-type: none"> 1. Too much pressure being applied to work piece. 2. Full width of belt not being used. 	<ol style="list-style-type: none"> 1. Reduce pressure on work piece. 2. Stroke across sanding belt using full width of belt surface.

Replacement Parts

This section provides exploded view illustrations that show the replacement parts for the Wilton Model 4210 Belt/Disc Sander. Also provided are parts listings that provide part number and description. The item numbers shown on the illustration relate the item number in the facing parts listing.

Order replacement parts from:

WHM TOOL GROUP

2420 Vantage Drive
Elgin, Illinois 60123
Ph.: 800-274-6848
www.wmhtoolgroup.com

To order parts or reach our service department, call 1-800-274-6848 between 7:30am and 5:30pm (CST), Monday through Friday. Having the Model Number and Serial Number of your machine available when you call will allow us to serve you quickly and accurately.

Assembled View and Parts Listing of Stand – Model 4210 Belt and Disc Sander

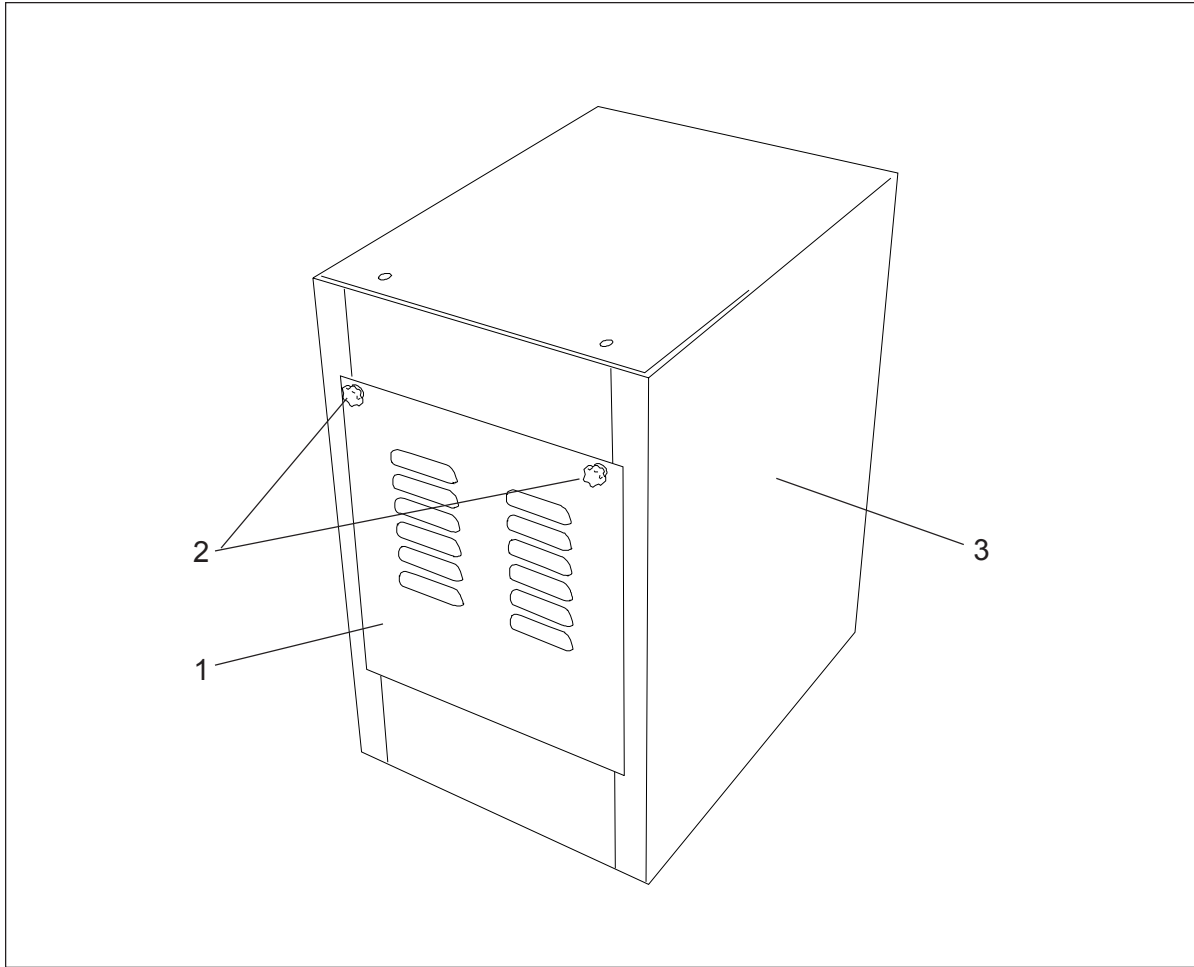

Ref. No.	Part Number	Description	Qty.
1	5513476	Panel, Access	1
2	5513477	Knob	2
3	5515307	Stand, Complete	1

Exploded View – Wilton Model 4210 Belt & Disc Sander

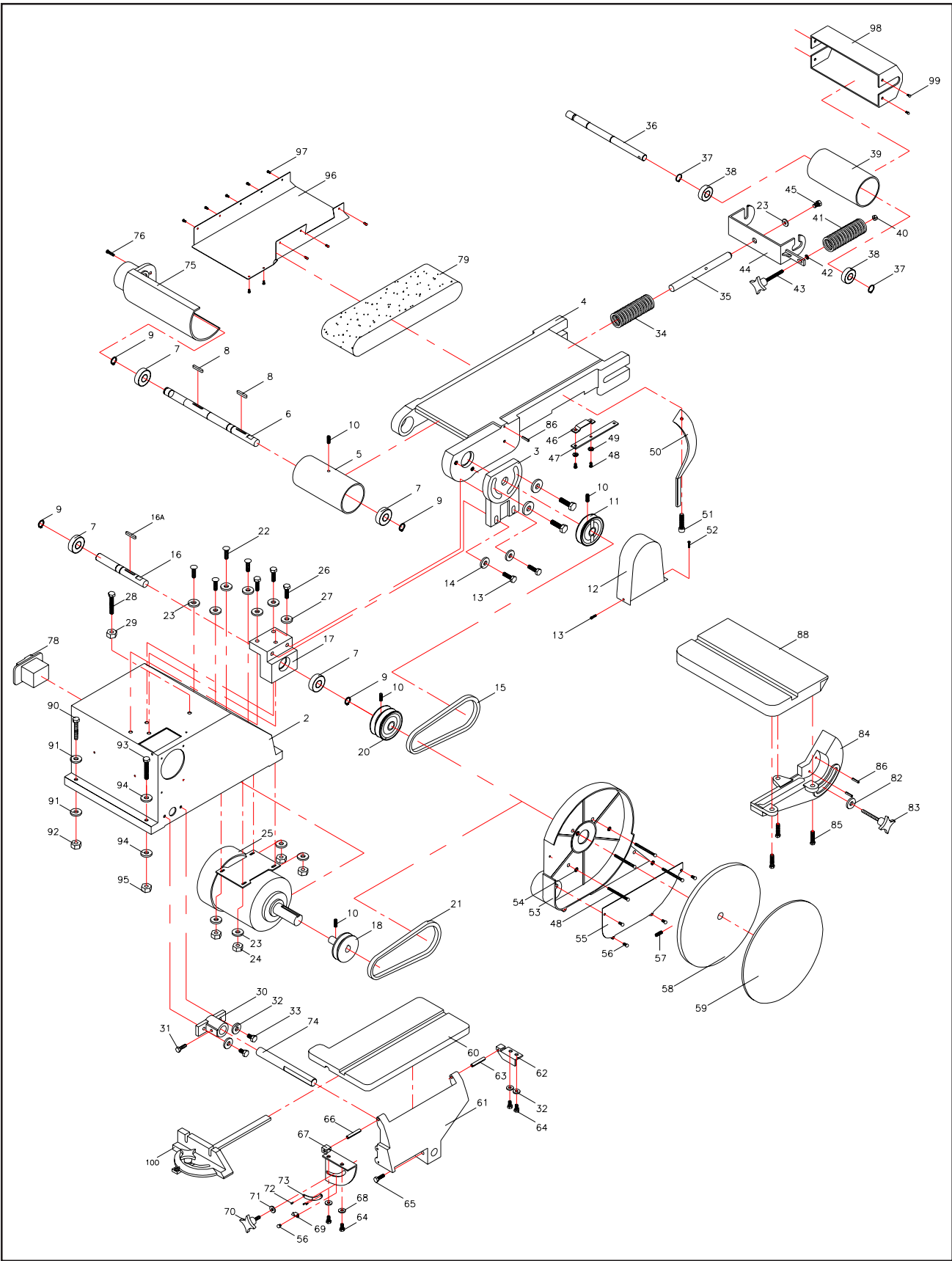

Parts Listing – Wilton Model 4210 Belt & Disc Sander

Ref. No.	Part Number	Description	Qty	Ref. No.	Part Number	Description	Qty
2	5513011	Base	1	57	5513067	Screw, Set (6 X 10 MM)	1
3	5513012	Bracket	1	58	5512765	Disk, Aluminum	1
4	5513013	Platen	1	59	5513071	Garnet Disk 10": 80 Grit (Standard)	1
5	5513014	Drum, Drive	1			Also available:	
6	5513015	Shaft, Drum Drive	1		5513073	100 Grit	1
7	5513016	Bearing (6203ZZ)	2		5513075	120 Grit	1
8	5513017	Key	1	60	5513077	Table, Side	1
8A	5513028	Key	1	61	5513078	Support, Table	1
9	5513018	Ring, Retaining (S-17)	2	62	5513079	Bracket, Table Support	1
10	5513019	Screw, Set (1/4 X 3/8)	1	63	5513080	Pin, Spring	1
11	5513020	Pulley	1	64	5513081	Screw (1/4 X 3/8)	4
12	5513021	Cover, Pulley	1	65	5513082	Screw, Hex (5/16 X 1)	1
13	5513022	Screw (5/16 X 1-1/2)	4	66	5513083	Pin, Spring	1
14	5513023	Washer, Plain (5/16)	4	67	5513084	Bracket, Table Support	1
15	5513024	V-Belt (A-18)	1	68	5513085	Washer, Flat	2
16	5513025	Shaft, Drive Pulley	1	69	5513086	Pointer	1
17	5513026	Bracket	1	70	5513087	Knob	1
18	5513027	Pulley, Motor	1	71	5513088	Washer	1
20	5513029	Pulley, Idler	1	72	5513089	Rivet	3
21	5513030	V-Belt (A-25)	1	73	5513090	Scale	1
22	5513031	Screw (5/16 X 3/4)	4	73A	5513091	Pointer	1
23	5513032	Washer, Flat (5/16)	8	74	5513092	Rod, Table Support	1
24	5513033	Nut, Hex (5/16)	4	75	5513093	Guard, Belt	1
25	5512767	Motor, 1-HP	1	76	5513094	Screw (3/16 X 5/8)	1
26	5513035	Screw, Hex (3/8 X 1)	3	77	5513095	Cover, Sanding Belt*	1
27	5513036	Washer, Flat (3/8)	3	77A	5513096	Screw, Cap*	8
28	5513037	Screw (3/8 X 1-1/2)	1	78	5512766	Switch	1
29	5513038	Nut, Jam	1	79	5051841	Belt, Abrasive(6 x 48) 80 Grit (Standard)	1
30	5513039	Bracket, Mounting	1			Also available:	
31	5513040	Screw (5/16 X 1)	1		5512764	100 Grit	1
32	5513041	Washer (1/4)	6		5513103	150 Grit	1
33	5513042	Screw, Hex (1/4 X 3/4)	2	82	5513107	Washer	1
34	5513043	Spring (1/4)	1	83	5513108	Knob (1/4 X 1-1/2)	1
35	5513044	Shaft	1	84	5512763	Bracket, Table	1
36	5513045	Shaft, Driven Drum	1	85	5513110	Screw (5/16 X 1-1/2)	3
37	5513046	Ring, Retaining (S-15)	2	86	5513111	Pin (4 X 15)	1
38	5513047	Bearing (6202ZZ)	2	88	5513113	Table, Sanding Belt	1
39	5513048	Drum, Driven	1	89	5513114	Wrench*	1
40	5513049	Nut (1/4)	1	90	5513115	Screw, Socket Head	2
41	5513050	Spring	1	91	5513116	Washer, Flat	2
42	5513051	Washer, Flat	1	92	5513117	Nut, Hex	2
43	5513052	Rod, Threaded, Belt Tracking Adjustment	1	93	5513118	Screw, Hex Head	2
44	5513054	Support, Driven Drum	1	94	5513119	Washer, Flat	2
45	5513055	Screw (5/16 X 1/2)	1	95	5513120	Nut, Hex	2
46	5513056	Bracket	1	96	5513479	Cover, Belt	1
47	5513057	Bar	1	97	5513480	Screw, Socket Head	8
48	5513058	Screw (3/16 X 1/2)	6	98	5514639	Guard, Belt	1
49	5513059	Washer (3/16)	2	99	5514640	Screw	4
50	5513060	Lever, Belt Tension	1	100	5517426	Gauge, Miter	1
51	5513061	Screw (5/16 X 1-1/4)	1		5515308	Head, Complete	1
52	5513062	Screw (3/16 X 3/8)	2				
53	5513063	Guard, Disk	1				
54	5513064	Washer, Lock (3/16)	4				
55	5513065	Plate, Cover	1				
56	5513066	Screw (3/16 X 1/4)	5				

* Part not shown.

Wiring Diagram

4210 ELECTRICAL SCHEMATIC - 115V

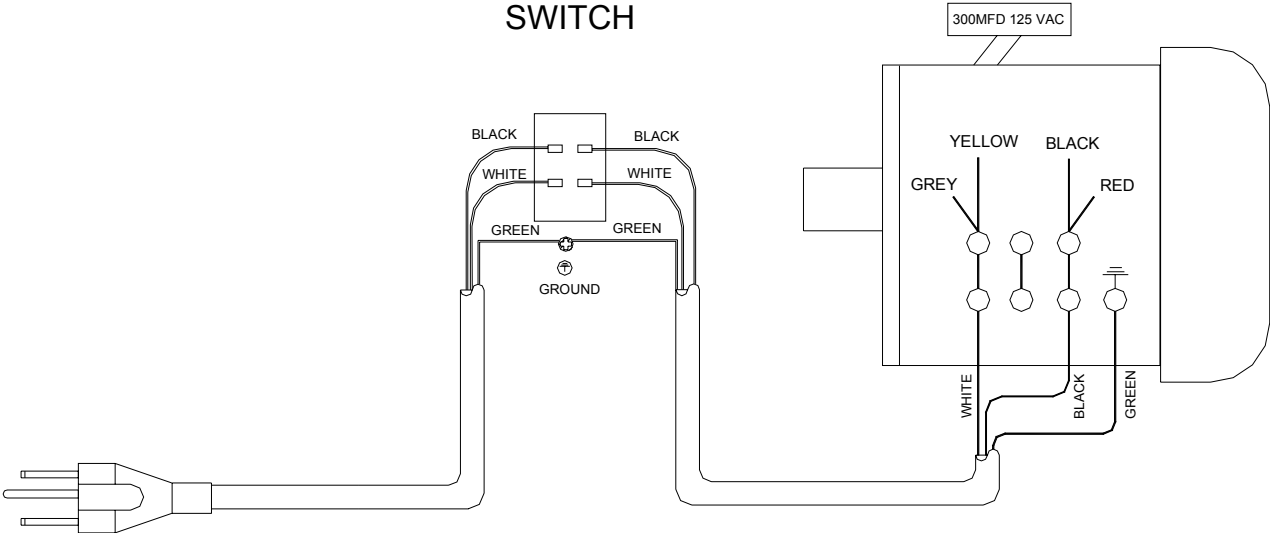

4210 ELECTRICAL SCHEMATIC - 230V

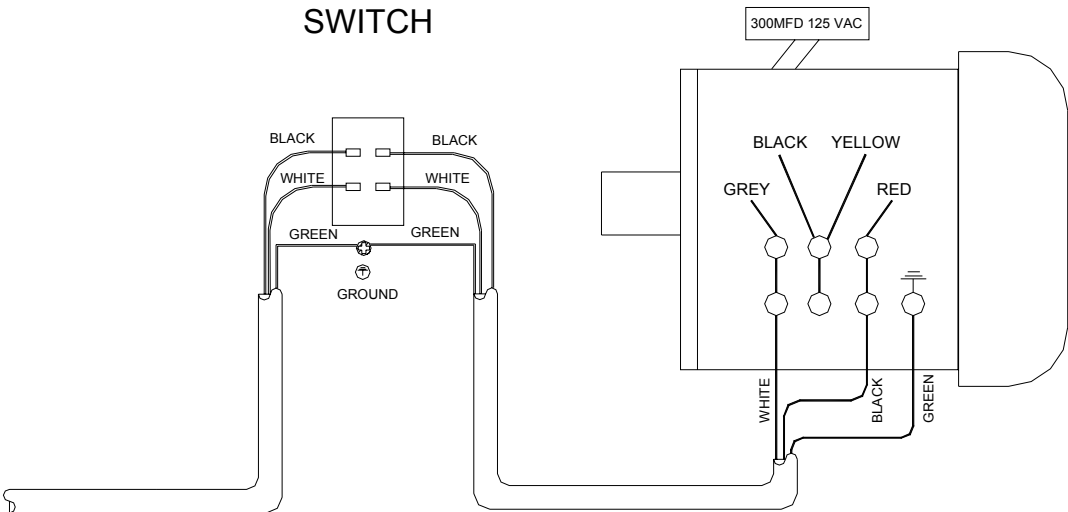

Notes

Notes



WHM TOOL GROUP
2420 Vantage Drive
Elgin, Illinois 60123
Ph.: 800-274-6848
www.wmhtoolgroup.com